

2007 INCARACE BOMBERS

CAR CONSTRUCTION RULES AND REGULATIONS

INTRODUCTION

Formerly known as Rookie Bangers, this formula is especially designed to encourage new drivers to Stadium Racing and to enjoy the atmosphere and excitement of driving without a large financial investment, or for drivers who feel they cannot give the commitment required to compete at a very high level in the other various formulas available. Drivers who have achieved high success in any other senior type formula over the past five years cannot compete in the Bomber formula. All licence applications will be reviewed by the Promoter and it must be understood that applications may be refused if it is considered that the prospective driver is too experienced for this entry level formula. A "Pay to Race" licence is available for those drivers who wish to try the formula and do not wish to buy a full licence. Day Licences are not allowed.

TYPE OF RACING

Bombers is intended to be a **LIMITED CONTACT** formula only. **LIGHT CONTACT ONLY** will be permitted. This means that you can push a car from behind, spin a car to the inside of the track, but you **MUST NOT follow a car into the safety fence, or lean or spin a car into the safety fence.**

VIOLATIONS

When referring to the engine, gearbox, differential, mechanical or construction, rules and regulations the principle will always be: Unless permission is specifically granted to make modifications, or any variation, nothing may be done to alter or change in any way the standard Parts.

Unless these rules state you can do it, you **CANNOT DO IT.**

Cars, Engines and Fuel will be checked on a random basis and all drivers must be prepared to have their engine stripped for examination at any time. If the driver does not have the expertise to do it, then he/she must provide someone to do it for them. Refusal to allow the engine strip may result in a ban of up to one year from all formulas.

Violations will result in an immediate suspension of all racing facilities and any refusal will also result in an immediate suspension.

All car and engine specifications will be taken from the Technical Service Data book for cars as published by Glass's Guide Service Limited.

It is the drivers responsibility to check the legality of their own car prior to competing.

NB: Drivers are reminded that scrutineer checks can be carried out at any time and most certainly on all official Championships. If parts are suspected of being illegal, make sure you leave them with the promotion if you do not agree. If you refuse it will automatically make the parts illegal. It is the responsibility of the driver to prove to the promotion that the part is legal by the way of written proof of where the part originated. This must be done within 7 days, otherwise the part(s) in question will be deemed to be illegal and will result in immediate suspension from racing and referral for disciplinary action.

SCRUTINEERING

Arrival at the Raceway is required minimum 1 hour before the advertised start time to allow scrutineering to be carried out. You need to present your car to the scrutineering area to be checked, as soon as possible after arriving at the raceway. The driver must accompany the car, complete with racing overalls, crash helmet, race suit and race licence.

1. CARS ELIGIBLE

- ◆ Any Saloon/Hatchback/Estate/Coupe car or People Carrier of 1600cc or under, front or rear wheel drive. No Granadas, Toyota Starlets, Cortinas, Capris, Bluebirds or Mk V Escorts are allowed.

2. PREPARATION

- ◆ Remove all exterior mouldings/headlamps/door handles/mirrors.
- ◆ Remove all glass, interior trim, dashboard, head linings, door linings, floor coverings, passenger seats.
- ◆ All window mechanisms must be removed.
- ◆ It is recommended that all obsolete wiring be removed.
- ◆ Remove spare wheel carriers and tow bars if fitted.
- ◆ Grilles must be removed. No replacement, "home-made" grilles allowed.

3. BODYWORK

- ◆ Front wings may be trimmed below the front bumper level.
- ◆ DOORS must either be bolted, chained or roped. If bolted, a maximum of 12" x 12" plate, with a maximum of 5 bolts per plate.
- ◆ A DOOR PLATE MUST BE FITTED and should overlap the drivers door front and rear pillar by a minimum of 3" maximum 6". It should be made of steel plate 3/8" – 3/4" thick, and be a minimum of 10" wide, maximum 15" wide. It should be attached to the car with a minimum of 4 x 3/4" bolts, with large washers on the inside with at least one bolt on each of the door pillars.
- ◆ Bonnets may be removable but must be securely fixed front and back with bonnet locking pins of some form. **If bolts are used a maximum thread size of 16mm, with maximum size of washer 4" or 4"**, i.e. NO LARGE BANGER OR SHUTTERING BOLTS (DAGGY BARS) OR PLATES OR WASHERS. No crush tubes allowed. Bolts must go through inner flitch or slam panel i.e. not through chassis. A maximum of 4 bolts may be used.
- ◆ Triangular corner plates or straps may be used to secure the rear of the bonnet by bolting or welding (1/8" thick). Plates or straps must be placed no further than 12" across or down from the back edge and side of the bonnet. In this case you may only use two bolts at the front.
- ◆ Sun roof apertures must be plated over (riveted or welded)
- ◆ No foam filled panels
- ◆ No roof spoilers or aerofoils allowed.
- ◆ Front and rear bumpers may be removed. ALL PLASTIC front and rear bumpers MUST BE removed.
- ◆ All holes in the front bulkhead must be filled to provide a firewall between the engine and driver.
- ◆ No armouring.

4. PAINTWORK

- ◆ Drivers should NOT paint their cars in team colours OR IN SIMILAR COLOURS TO THAT OF OTHER CARS.
- ◆ Refusal to comply with this regulation in full will result in all cars, which in the opinion of the Scrutineer/Steward are similar in appearance, being withdrawn from the meeting.
- ◆ BRIGHT colours are recommended; a good general appearance is required before any car will be allowed to race.
- ◆ Cars can be neatly sign written, but nothing should be painted or sign written on the car which could cause offence.

5. SUSPENSION

- ◆ Must remain standard.

6. ROLL BAR

- ◆ You must fit a single "hoop" roll bar in support of the door pillars, securely bolted to the roof and floor with a minimum size bolt of 3/8" (8mm) and suitable washers.
- ◆ The hoop must be one piece or two uprights on one top bar of a welded construction.
- ◆ One cross bar is compulsory, a second is optional; these must be welded or bolted to the uprights.
- ◆ THE ROLL BAR MUST NOT HAVE ANY REAR SUPPORTS but may have extensions no further forward than the B post (see diagram below). If used, these must be bolted through the B post.

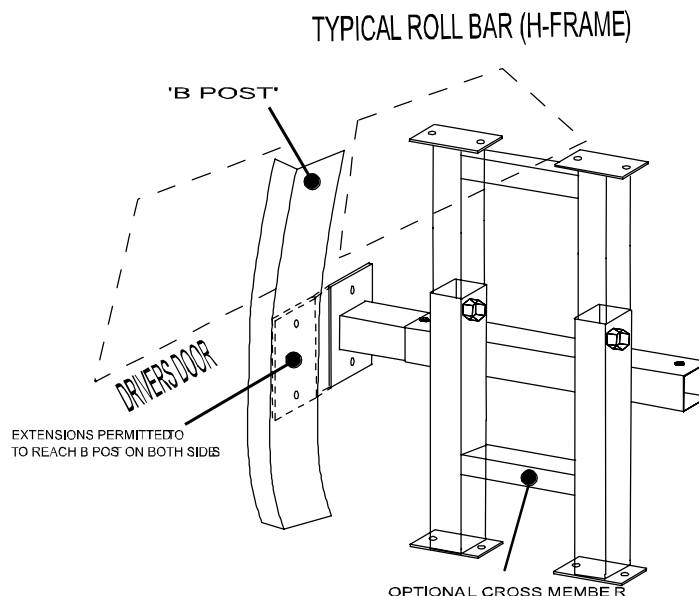

- ◆ The minimum size for roll bar is 2" (50mm), maximum size 4" (100mm), minimum thickness 3mm (75mm).
- ◆ Crossbars must have a 5" (125mm) square end plate fitted.
- ◆ The roll bar cross bars must be straight and no protrusion of cross bars must exist.

- ◆ Each upright must have a maximum of two bolts on each side to the floor and one each side at the top.
- ◆ No scaffold clamps allowed, all adjustable feet must be welded to the cage.
- ◆ The seat must be supported and secured at shoulder level to the cage, you may fit the 2nd cross bar in support of the seat just below the window aperture or weld a frame on the cage to support the seat at the top.

7. ENGINES

- ◆ A 1.5mm overbore is allowed.
- ◆ The engine must be fitted with a metal catch tank of 1 litre minimum capacity connected to the engine breather system.
- ◆ Air filters are free.
- ◆ All parts must remain as manufactured within the engine type used such that the compression ratio remains standard to that engine type – i.e. the cylinder head and block must originate from the same cc of engine.
- ◆ ***The engine and gearbox must be the one originally fitted to the Manufacturers range.***
- ◆ Pistons must be standard – no modifications. Pistons and rings may be size matched with the appropriate overbore as specified above.
- ◆ Fly wheels must be standard – no lightening allowed.
- ◆ Alternators may be removed.
- ◆ Only a standard camshaft to the engine is allowed, or a replacement item with the same geometry (lift, duration etc)
- ◆ The inlet and exhaust manifolds must be standard to the engine. These may be de-carbonised but not highly polished or ported ie. No removal of casting marks etc.
- ◆ Sumps may be baffled to prevent oil wash away from oil pick up point.
- ◆ ***Engine and Gearbox mountings may be replaced or strengthened, but must occupy the original fixing positions.***

DRIVERS MUST BE REMINDED THAT ALL ENGINE PARTS MUST REMAIN STANDARD OR AFTER-MARKET

8. CARBURETTOR

- ◆ Must remain standard to the manufacturers model range.
- ◆ Cold start devices may be removed.
- ◆ Re-jetting is permitted.
- ◆ ***Vehicles fitted with a single point injection can be used providing they are fitted using the standard Banger fuel system and the fuel pump is replaced with a standard High Pressure Facet pump.***

9. GEARBOX/DIFFERENTIAL

- ◆ Gearbox must be as manufactured to the same model of vehicle, i.e. you cannot exchange a four speed gearbox onto an engine manufactured only with a five speed gearbox, or vice-versa.
- ◆ Axle and ratio must be as manufactured.
- ◆ No locked differentials or limited slip differentials are allowed.

10. FUEL SYSTEM

- ◆ Manual fuel pumps may be replaced with electric pumps.
- ◆ The original petrol tank must be removed and replaced with a maximum size 2-3 gallon safety tank fitted inside the car either on, under or behind the roll bar, not on the parcel shelf. Before fitting, the tank should be carefully checked to see that it cannot leak when inverted or on its side and the outlet must be from the top of the tank. The vent pipe from the top of the tank must be terminated below the floor level of the car. The fitting of a one way valve is advisable.
- ◆ All fuel lines must be in good condition and securely clamped.
- ◆ A manual shut-off tap must be fitted within reach of the driver when strapped in the car.
- ◆ All fuel tanks must have a metal screw top.

11. COOLING SYSTEM

- ◆ Radiators are free but must be fitted in original position
- ◆ No steam tanks allowed.
- ◆ Thermostat may be removed.
- ◆ No oil coolers, heater matrix, or any additional water coolers allowed.

12. EXHAUST SYSTEM

- ◆ No car will be allowed to race without an exhaust system
- ◆ The down-pipe must be standard but the rest of the system is free and must be suitably silenced.
- ◆ The system must terminate at the rear of the vehicle.
- ◆ All drivers must be aware that if your car is above the required noise level you will not be allowed to race. The Stewards decision is final.

13. BATTERY AND ELECTRICAL

- ◆ Batteries must be bolted or clamped in position and completely covered with rot-proof material to prevent acid leakage. Batteries should be fitted on, under or behind the roll bar, not in the footwell. If batteries are secured in a box the maximum size is to be 18" x 12" or equivalent.
- ◆ All wiring must be fully insulated.
- ◆ Electrical starters must be fitted and in working order.
- ◆ Ignition and starting must be activated through an insulated switch, not by connecting bare wires together. A battery cut off switch **MUST** be mounted on the roll cage on the near side of the car, the switch must be wired to the earth side of the battery.
- ◆ Electronic ignition is permitted within the manufacturers range eg. Ford – Ford

14. BRAKES

- ◆ *Brakes must be effective.*

15. WHEELS & TYRES

- ◆ Any standard road wheel may be used up to 6.5"J that fits safely.
- ◆ All four wheels and tyres **MUST** be of the same type and diameter and **ALL** wheel nuts must be fitted.
- ◆ Hub-caps and wheel weights **MUST** be removed.
- ◆ Only conventional standard road tyres may be used up to a maximum diameter of 195mm, minimum 60 series.
- ◆ No competition tyres of any kind whatsoever.
- ◆ Any tyre with buffed markings will not be accepted.
- ◆ The use of tyre gaiters are allowed.
- ◆ No Avon 7.3's, Avon Turbospeed, Yokohama's, Colways (except road remoulds), M & S, Knobbles, or slicks.

Note: The promotion reserve the right to review the regulation relating to wheels and tyres at any time.

16. DRIVER'S SEAT

- ◆ A seat with a head restraint must be fitted. The seat must be securely mounted at shoulder height to the cross bar or to the rollover bar and bolted securely to floor.

17. SAFETY EQUIPMENT

- ◆ A full shoulder-type safety harness as approved by ORCi for Bangers with lap-straps must be fitted and bolted to the floor.
- ◆ A minimum of a four point buckle fixing must be used with a minimum of 3 floor fixings. A secure part of the floor or cage (including the seat bar) are recommended anchor points.
- ◆ Single point buckle fixing harnesses are not allowed.
- ◆ A suitable head restraint must be fitted to the roll cage or seat.
- ◆ A 1Kg Dry Powder Gauge Fire Extinguisher is highly recommended and if fitted, this should be in a tube with a spring top and should be within easy reach of the driver. Old type BCF (green) type extinguishers are not allowed.
- ◆ Plastic or Polycarbonate helmets (i.e. British, European or Snell) of any type are not permitted.
- ◆ Helmets must be of a minimum standard as directed by British Oval Racing Safety Executive (B.O.R.S.E). These are BS6658/85 Type A, BS6658 Type A/FR, FIA8860-2004, Snell SA2000, Snell SA2005, SFI Foundation 31.1, SFI Foundation 31.2 or E2205 European Standard. Shatterproof goggles/visors must be worn although tinted visors are not advisable.
- ◆ Neck braces are recommended.
- ◆ Fireproof Balaclavas are highly recommended and must be marked appropriately.
- ◆ Fireproof gloves are **MANDATORY** and must be marked appropriately.
- ◆ Only flame retardant racing suits must be worn. On wet meetings waterproofs may be worn as overgarments.
- ◆ The drivers seat must be secured and supported to the roll cage at shoulder level by bolting or tying.
- ◆ The 2nd roll cage cross brace may be used to support the seat, but it must be set below the bottom of the window aperture or you may construct and weld a frame on to the cage to support the seat.
- ◆ The drivers seat must be a standard production seat, not a racing seat.

18. RACING NUMBERS

- ◆ Both front doors **MUST** be painted white.
- ◆ Your racing numbers must be displayed on the bonnet facing the control tower and on both front doors in black, minimum height of 16" high x 2" wide brush strokes.
- ◆ You must also fit a fin plate to the roof of your car, minimum size 18" x 12" and a maximum size of 20" x 15". Your number must be on both sides of this fin plate, either white on a black background or black on a white background, no other colours allowed, no other writing allowed, minimum size 9" high x 1½" wide.

19. DRIVERS ELIGIBLE

- ◆ Each driver is only permitted one car per meeting, in Bombers and each car is only permitted one driver per meeting.

For further information contact :

**INCARACE Limited
P O Box 11999
Birmingham
B42 1WD**

Tel : 0121-357 7328

e-mail : info@incarace.co.uk

Fax/Booking Line : 0121-357 0007

E-mail Booking : bookin@incarace.co.uk

REVISED RULES FOR 2007 IN BOLD/ITALIC PRINT

ITEMS MARKED ~~STRIKETHROUGH~~ ARE NO LONGER ALLOWED

2007 Bombers Technical Specifications, Issue 1, Dated 29th November 2006